

## From consulting to training: **complete support by TVN Tech**



### Consulting

We offer a personalized approach and strategic support, guiding our clients in choosing the solutions best suited to their production needs.



### In-house production

TVN Tech machinery is designed and manufactured internally, starting from a thorough research process and the selection of the most durable and high-performance materials.



### Installation

We make sure everything is ready for the machine startup. Our team of experts oversees the installation to guarantee a smooth implementation.



### Training

Through a dedicated training service, we provide our clients with all the necessary skills to make the most of each machine.

CUTTING-EDGE  
TECHNOLOGY  
SINCE 1982

## TVN TECH S.r.l.

Via XXV Aprile, 72  
Zona Ind.le Monte San Savino  
(AREZZO) ITALY  
Tel. +39 0575 810157 / 849149

[www.tvntech.it](http://www.tvntech.it)

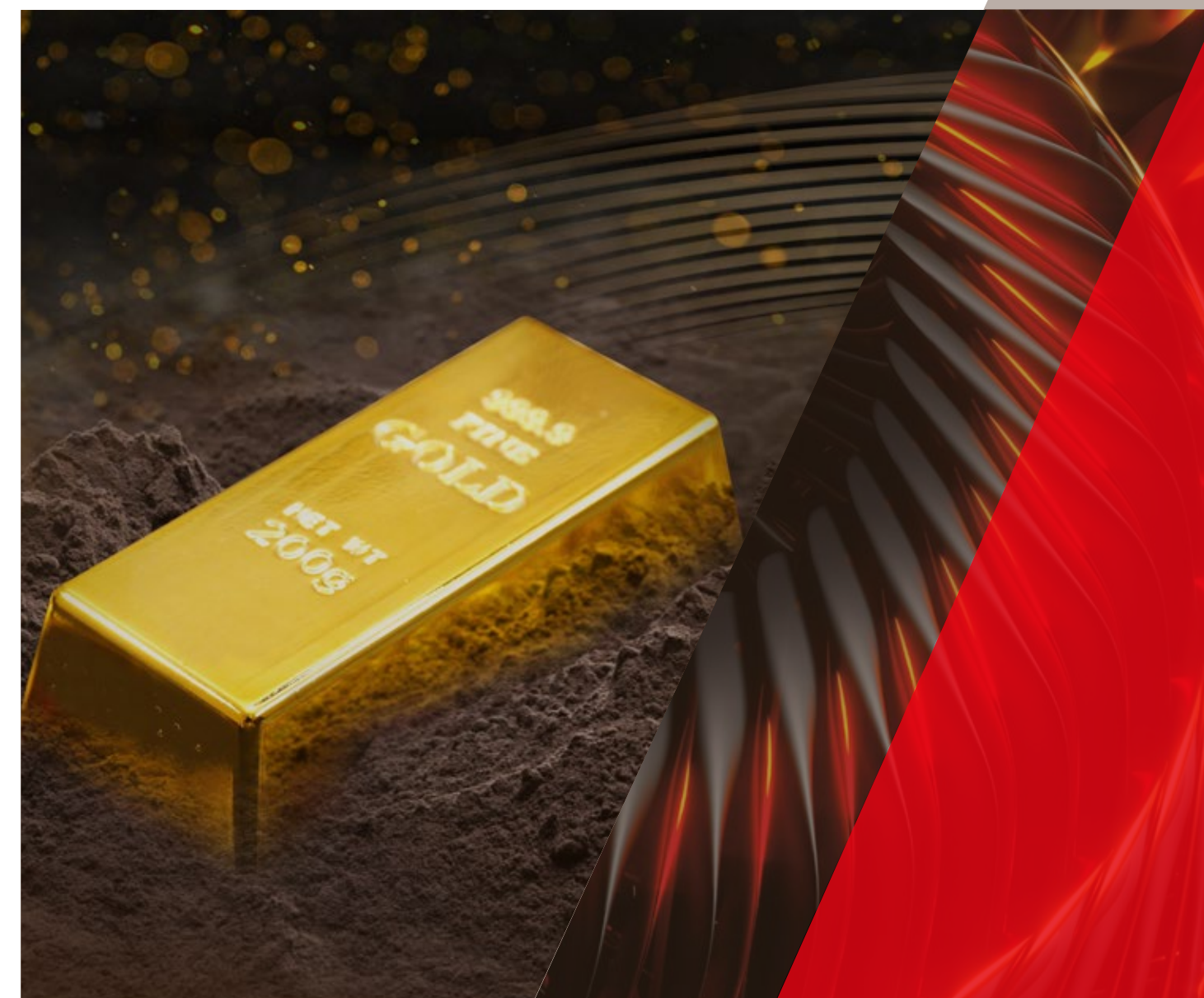

COMPLETE LINES  
**ASH treatment**

CUTTING-EDGE TECHNOLOGY SINCE 1982

# HOMOGENEITY AND CERTAINTY OF RESULTS:

## the complete solution for ash treatment in precious metal recovery

### HOMOGENEITY OF RESULTS

- The powder mixer ensures a perfectly homogeneous batch, minimizing waste and product variation.

### CONSISTENT QUALITY

- The line guarantees maximum correspondence between the initial ash sample and the result of processing.

### MAXIMUM DURABILITY

- Each model is built according to CE standards with first choice components.

### MAINTENANCE WITHOUT MACHINE CHANGE

- TVN Tech machines are designed to return to 100% of their capabilities with ordinary and extraordinary maintenance.

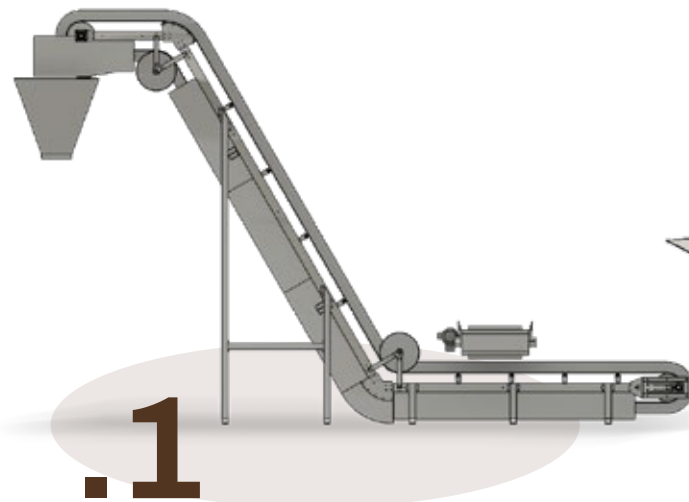

.1

### CONVEYOR BELT

The line can be automated with the integration of a conveyor belt that optimizes processing times and increases productivity.

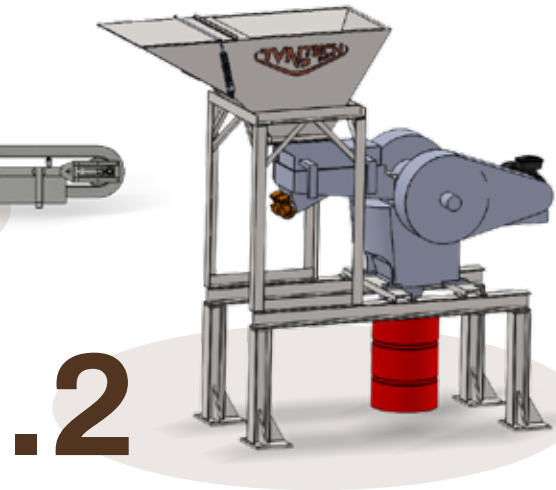

.2

### JAW MILL

To pre-mill crucibles, borax, and recovery material after incineration and speed up the subsequent pulverization.

**The grinding mill ensures a consistently high-quality finished product**  
The stainless-steel mesh nets on the rotor ensure optimal and constant filtering throughout the entire process.

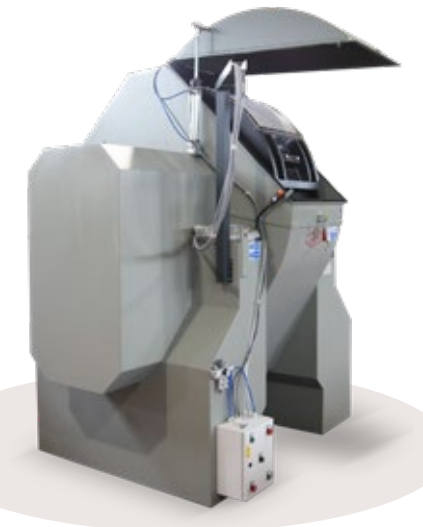

.3

### GRINDING MILL

With a rotor in special double-armored steel, moved by a motor with hydraulic joint and transmission with gears in an oil bath.



.4

### AUTOMATIC CONVEYOR SYSTEM

A state-of-the-art system for the automatic transportation of raw materials, fully customizable.



.5

### MIXER

The transmission in oil bath gears and the coupling of the motor with the hydraulic coupling provide great reliability and excellent mixing performance.

**The powder mixer ensures homogeneous results**  
Inside the central tank, the powders are mixed through the rotary motion of a cochlea specially designed to make this process extremely uniform and homogeneous.



- › The complete line is optimized to achieve the best results. However, all TVN Tech machines can be purchased individually as they work independently.



Discover the complete line for ash treatment on our website

